

Keep this
manual onboard!



User Manual

Including Installation For Remote Controls
RCT-20E, RCT-21E, RCT-22E, RCT-23-E
RCR-2E, RCRS-2E



SLEIPNER AS

P.O. Box 519
N-1612 Fredrikstad
Norway
www.sleipnergroup.com

DOCUMENT ID: 2955

REVISION: 10

DATE: 2021

LANGUAGE: EN



To download your language go to www.sleipnergroup.com

Considerations and Precautions	3
Signals Considerations and Precautions	3
Installation Manual	
Remote Control Kits	4
Panel Layout & Functions	5
Technical Specifications	6
S-Link Technical Specifications	6
Receiver Installation	7
Technical Wiring Diagram	8 - 11
Output Signals Diagram.....	12
Programming Additional Transmitters/ Remote Controls.....	13
S-Link Receiver Installation	14
Technical Wiring Diagram	15
S-Link Receiver Installation	16
Transmitter Installation and Battery Replacement.....	17
User Manual	
Important Thruster User Considerations and Precautions	18
Thruster Operation	19 - 20
Transmitter LED Operation and Alarm Indication	21
Receiver LED Indicator	21
S-Link Transmitter LED Operation and Alarm Indication	21
S-Link Receiver LED Indicator.....	21
Service and Support	22
Product Spare Parts and Additional Resources	22
Warranty statement	22
Patents	22

Products

SM126344		RCT-23E - Fjernkontrollsend.dbl.vinsj/thr
SM126317		RC-21E - Fjernkontrollsett baug/vinsj
SM126428		RC-23E - Fjernkontroll dbl.vinsj/thrust
SM126315		RCT-21E - Fjernkontrollsender baug/vinsj
SM126335		RC-20E - Fjernkontrollsett baug og hekk
SM126327		RC-22E - Fjernkontrollsett dbl. vinsj
SM126251		RCR-2E - Fjernkontrollmottaker
SM904984		RCT-20E - Fjernkontrollsender baug/hekk
SM126321		RCT-22E - Fjernkontrollsender dbl. vinsj

DECLARATION OF CONFORMITY

MC_0020



Sleipner Motor AS
P.O. Box 519, Arne Svendsensgt. 6-8
N-1612 Fredrikstad, Norway

Declare that this product with accompanying standard control systems complies with the essential health and safety requirements according to:

DIRECTIVE 2013/53/EU
DIRECTIVE 2014/30/EU
DIRECTIVE 2014/35/EU

It is the installers responsibility

When installing Sleipner equipment follow the outlined regulations/ classification rules (electrical/ mechanical) according to international or special national regulations. Instructions in this guide cannot be guaranteed to comply with global electric/ mechanic regulations/ classification rules.

Follow all health and safety laws in accordance with their local outlined regulations/ classification rules.

Before installation, it is important that the installer reads this guide to ensure necessary acquaintance with the product.

The recommendations made in this manual are guidelines ONLY, and Sleipner Motor AS (Sleipner) strongly recommend that before installation, advice is obtained from a naval architect familiar with the particular vessel and regulations/ classifications.

This manual is intended to support educated/ experienced staff and is therefore not sufficient in all details for professional installation. (NB: These instructions are only general instruction. If you are not skilled to do this work, please contact professional installers for assistance.)

All electrical work must be done by a licensed professional.

Faulty installation of Sleipner products will render all warranty given by Sleipner Motor AS void.

MC_0038

EN

Considerations and Precautions

MC_0105

IMPORTANT

If installing S-link products DO NOT connect any other control equipment to the S-link controlled products except Sleipner original S-link products or via a Sleipner supplied interface product made for interfacing with other controls. Any attempt to directly control or at all connect into the S-link control system without the designated and approved interface will render all warranties and responsibilities for the complete line of Sleipner products connected void and null. If you are interfacing by agreement with Sleipner and through a designated Sleipner supplied interface, you are still required to also install at least one original Sleipner control panel to enable efficient troubleshooting if necessary.

EN

Signals Considerations and Precautions

MC_0211

IMPORTANT

Sleipner has developed remote controls with approval in the EU and US markets. However, it is the Importers responsibility to comply with all restrictions and legislation on radio signals in the country to which it is imported.

Remote control kit RC-20U/E consists of:

- Receiver: Part no. RCR-2U/E
- Transmitter (incl. Battery): Part no. RCT-20U/E
- Holding bracket for transmitter unit: Part no. RC-HOLDER

*U For the USA configuration
*E For European configuration

**Remote control kit RC-21U/E consists of:**

- Receiver: Part no. RCR-2U/E
- Transmitter (incl. Battery): Part no. RCT-21U/E
- Holding bracket for transmitter unit: Part no. RC-HOLDER

*U For the USA configuration
*E For European configuration

**Remote control kit RC-22U consists of:**

- Receiver: Part no. RCR-2U/E
- Transmitter (incl. Battery): Part no. RCT-22U/E
- Holding bracket for transmitter unit: Part no. RC-HOLDER

*U For the USA configuration
*E For European configuration

**Remote control kit RC-23U consists of:**

- Receiver: Part no. RCR-2U/E
- Transmitter (incl. Battery): Part no. RCT-23U/E
- Holding bracket for transmitter unit: Part no. RC-HOLDER

*U For the USA configuration
*E For European configuration

**Remote control kit RCS-20U/E consists of:**

- Receiver: Part no. RCRS-2U/E
- Transmitter (incl. Battery): Part no. RCT-20U/E
- Holding bracket for transmitter unit: Part no. RC-HOLDER

*U For the USA configuration
*E For European configuration



Remote Transmitter

RCT-20(U/E) *U For the USA configuration
*E For European configuration



RCT-21(U/E) *U For the USA configuration
*E For European configuration



RCT-22(U/E) *U For the USA configuration
*E For European configuration



RCT-23(U/E) *U For the USA configuration
*E For European configuration

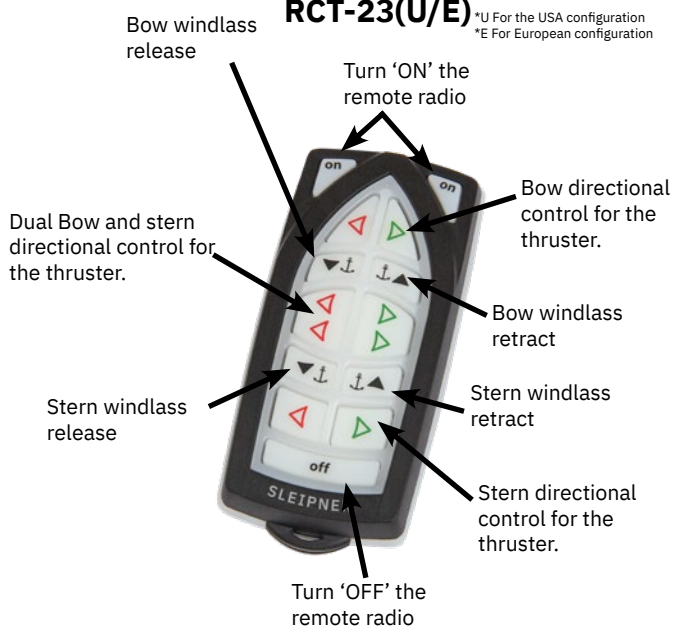

Receiver

RCRS-2(U/E) *U For the USA configuration
*E For European configuration



For S-Link configuration

RCR-2(U/E) *U For the USA configuration
*E For European configuration



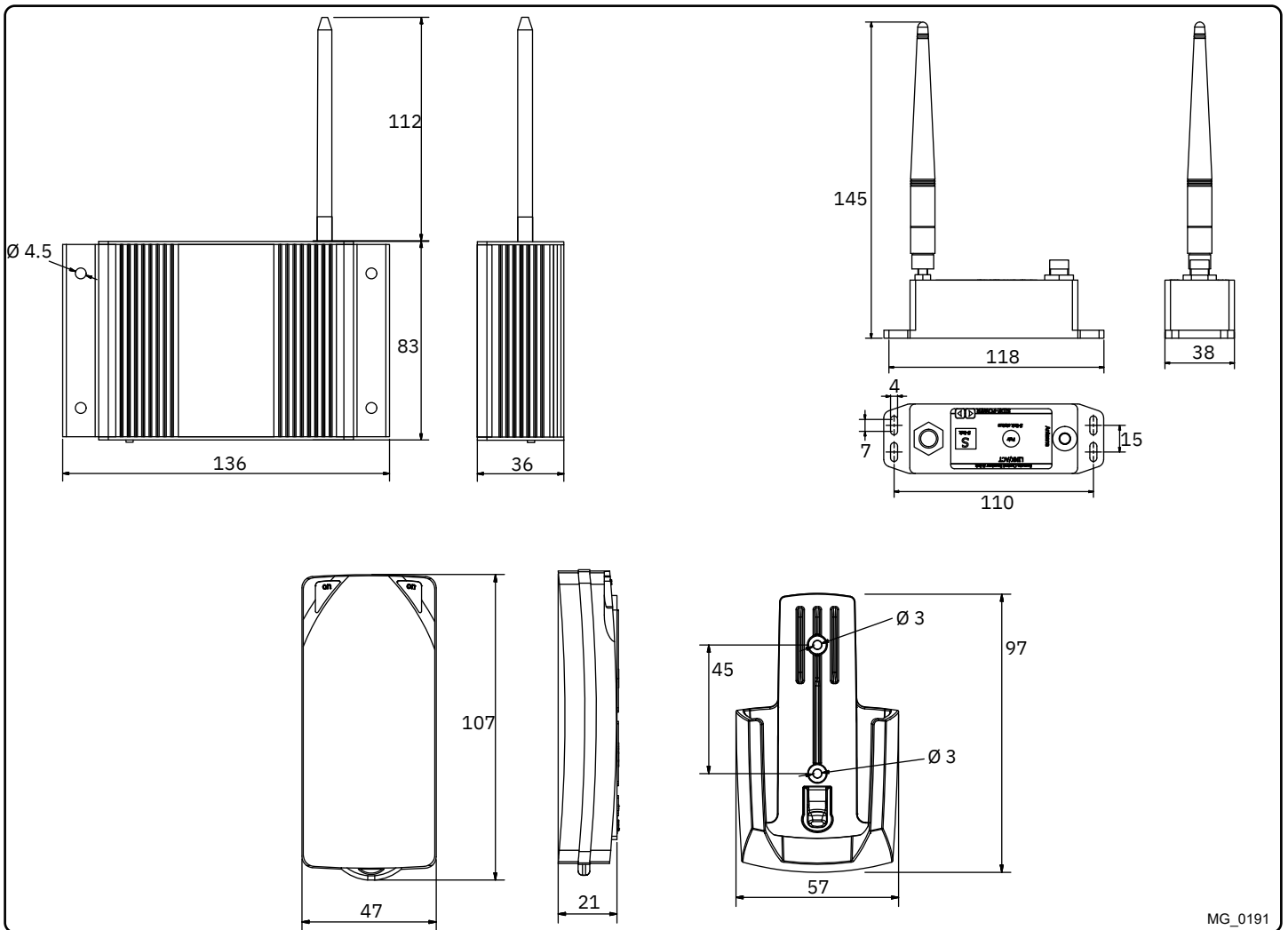

MG_0191

EN

Transmitter/Receiver - Technical Specifications

MC_0176

	Transmitter	Receiver
Power feed	1x3V battery (type: CR2032)	12V or 24V power source
Frequency (MHz)	868 MHz	868 MHz
RF-power	<10mW	<10mW
Operation temp.	-10°C / +55°C	-10°C / +55°C
HxWxD (mm)	107x47x21	83x136x36
Weight (g)	60	275
Voltage		8-30V
Standby power		<300mW
Load, max		4A

EN

S-Link Transmitter/Receiver - Technical Specifications

MC_0176

	Transmitter	Receiver
Power feed	1x3V battery (type: CR2032)	12V or 24V power source
Frequency (MHz)	868 MHz	868 MHz
Operation temp.	-10°C / +55°C	-10°C / +55°C
HxWxD (mm)	107x47x21	110x35x35
Weight (g)	60	170
Voltage		8-30V
Operating range	30m under normal operating conditions	



Mount the receiver by using the 4 holes

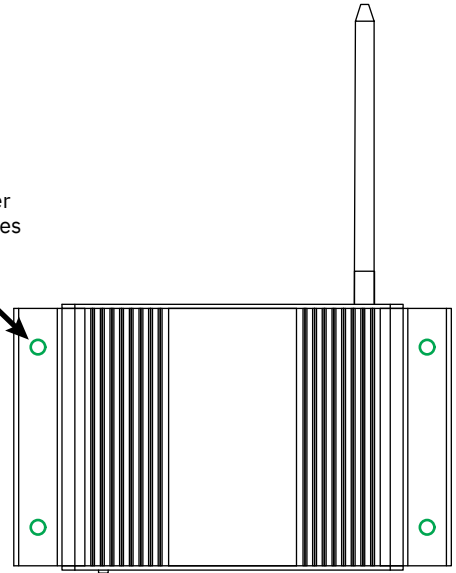

MG_0193

EN

Receiver Installation

MC_0177

! Please refer to the graphic for special considerations relating to your model !

- Install the receiver minimum 1 meter (3ft) from high power cables and data communication cables or other sources of electrical interference, i.e. navigation instruments, radio communication devices, electric motors and generators.
- Install the receiver minimum 1 meter (3ft) above sea level.
- Install the receiver outside of shielded areas for radio signals, i.e. boxes made of metals or other material with shielding properties.
- Install the receiver in a dry environment, where no condensation can enter the unit. (The receiver assembly is not waterproof.)
- Mount the receiver using the four holes.
- The receiver must have a separate power supply fitted with a 5 Amp fuse in the positive lead that has either a separate power switch or is shut off by the thrusters system main power switch. The receiver can not be powered by the thrusters/windlass control looms even if you find positive and negative lead there.
- Connect the supplied wiring harnesses to the receiver unit according to the wiring diagram. Connect thrusters and windlasses to the appropriate connectors according to the diagram.
- For use with other windlass brands, connections must be determined by the installer according to the out put signals diagram.

NB: Max. load on the windlass signal output is 4A! If the windlass requires more than 4A, use extra control relay.

IMPORTANT

Remote receiver power supply negative lead must be connected to the thrusters' negative lead. Bow and stern thruster must have a common negative. Power to the thrusters must be switched off during installation!



RCT-20(U/E)

IMPORTANT
Cables/wires must be cable tied well.

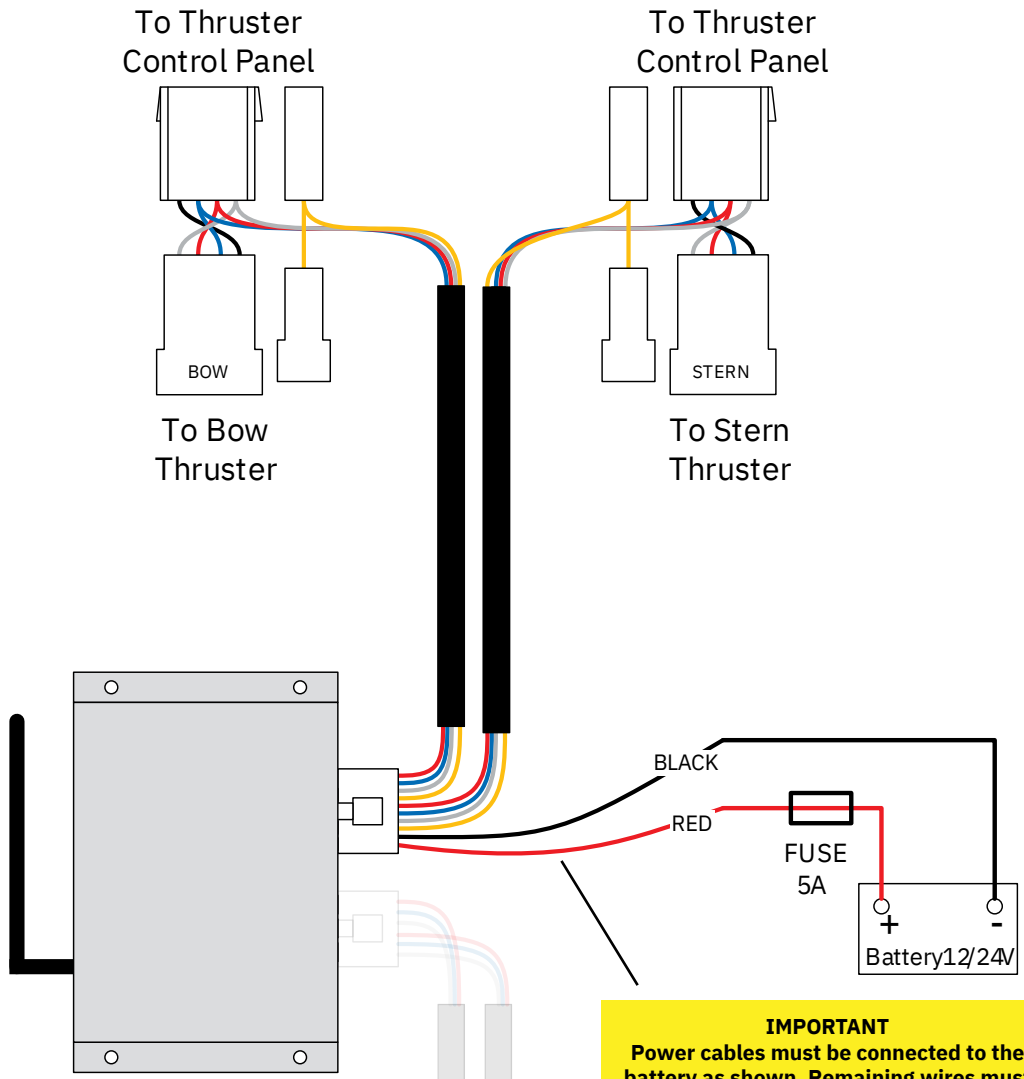

IMPORTANT
Power cables must be connected to the battery as shown. Remaining wires must be cable tied well.

Technical Wiring Diagram



RCT-21(U/E)

IMPORTANT
Cables/wires must be cable tied well.

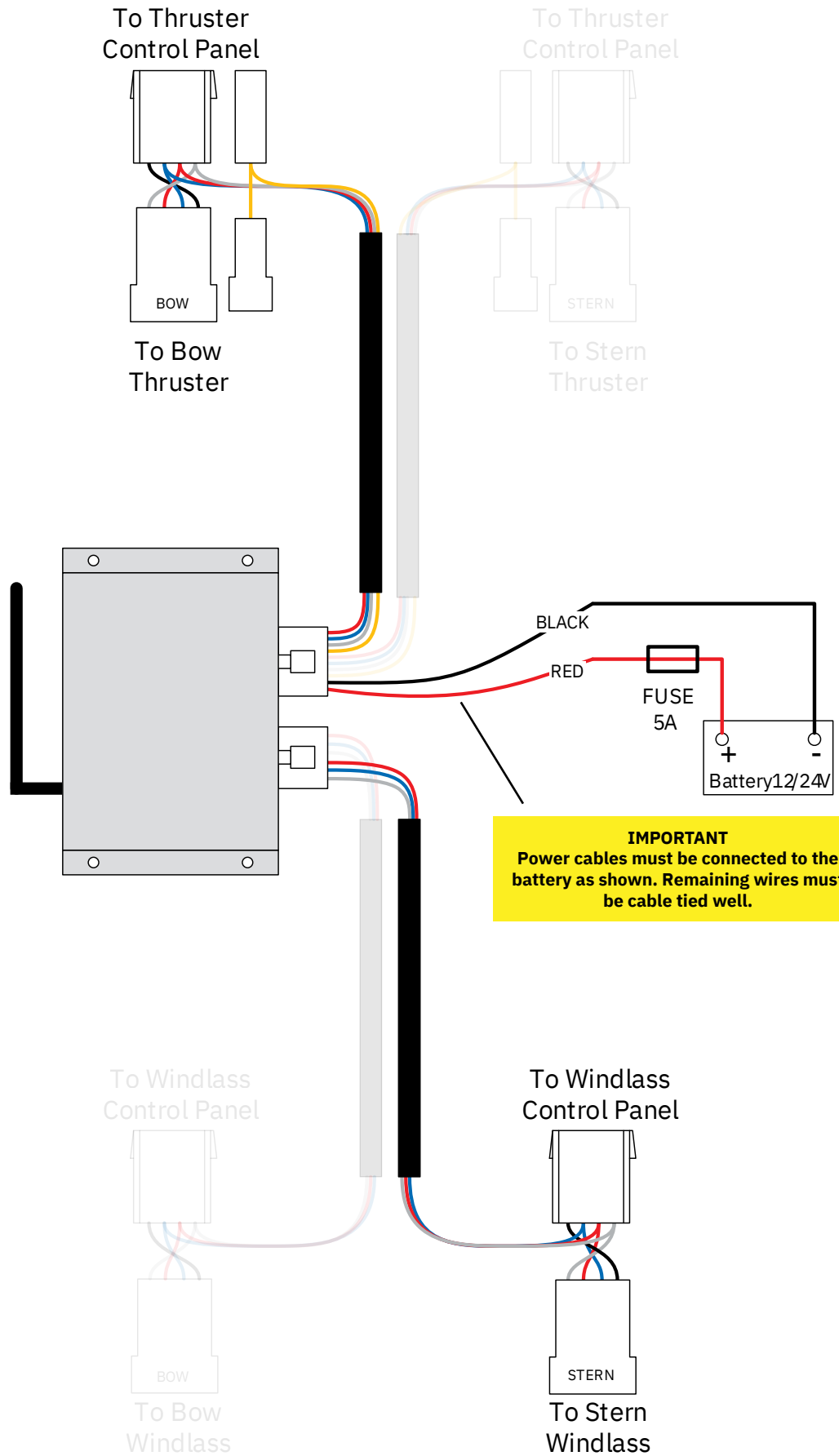

IMPORTANT
Power cables must be connected to the battery as shown. Remaining wires must be cable tied well.

Technical Wiring Diagram



RCT-22(U/E)

IMPORTANT
Cables/wires must be cable tied well.

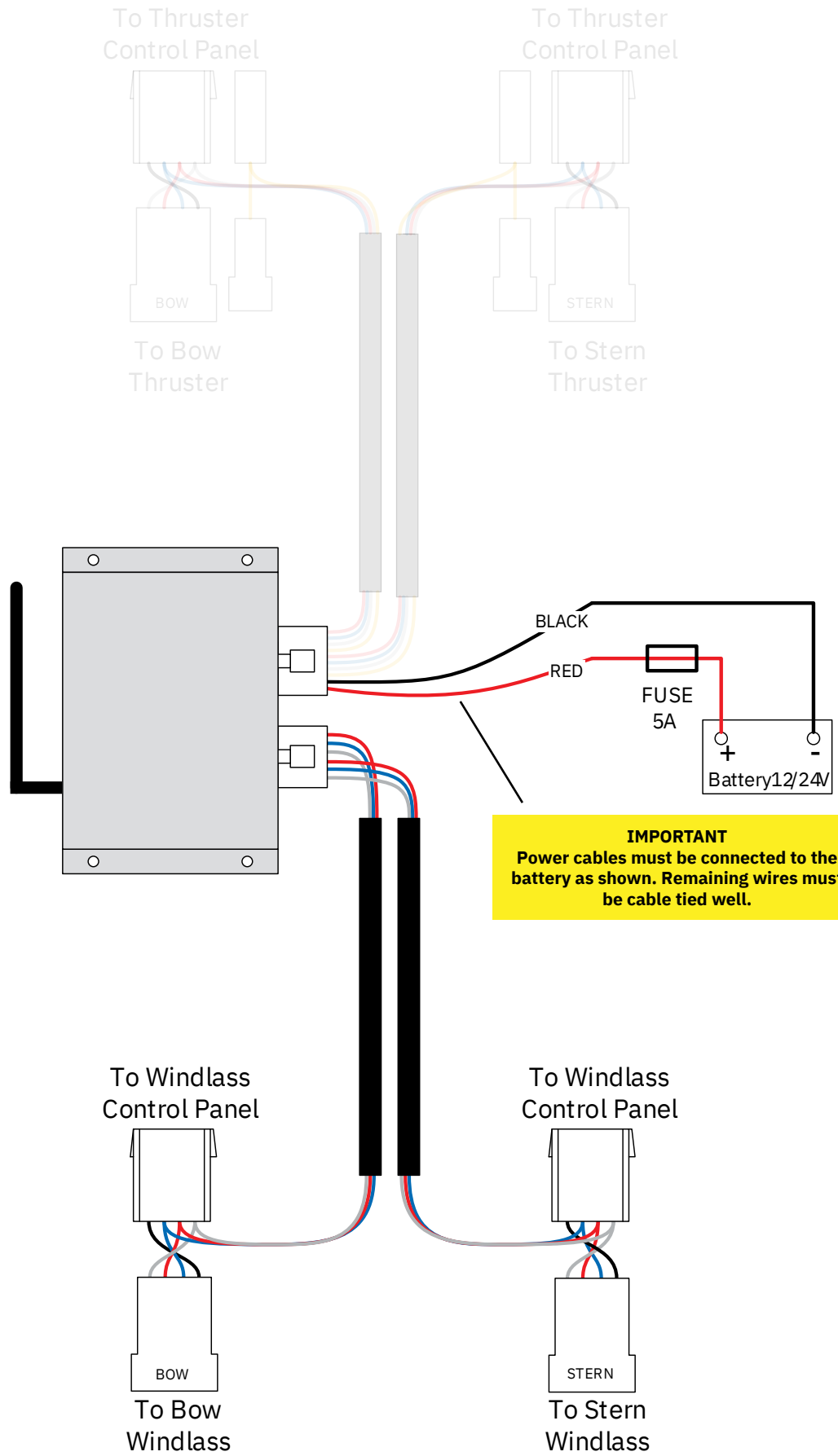

IMPORTANT
Power cables must be connected to the battery as shown. Remaining wires must be cable tied well.

Technical Wiring Diagram



RCT-23(U/E)

IMPORTANT
Cables/wires must be cable tied well.

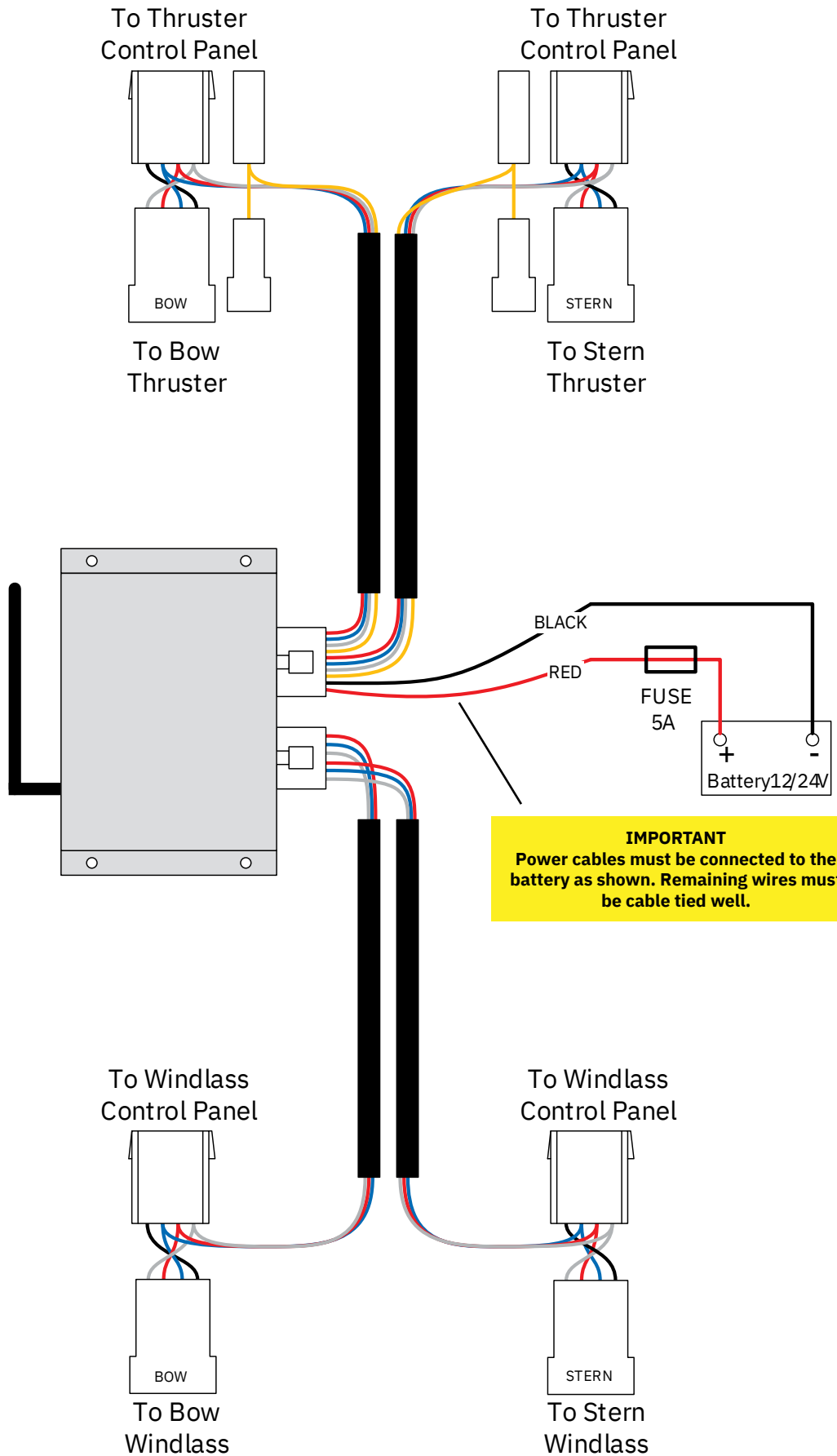

IMPORTANT
Power cables must be connected to the battery as shown. Remaining wires must be cable tied well.

Output Signals Diagram

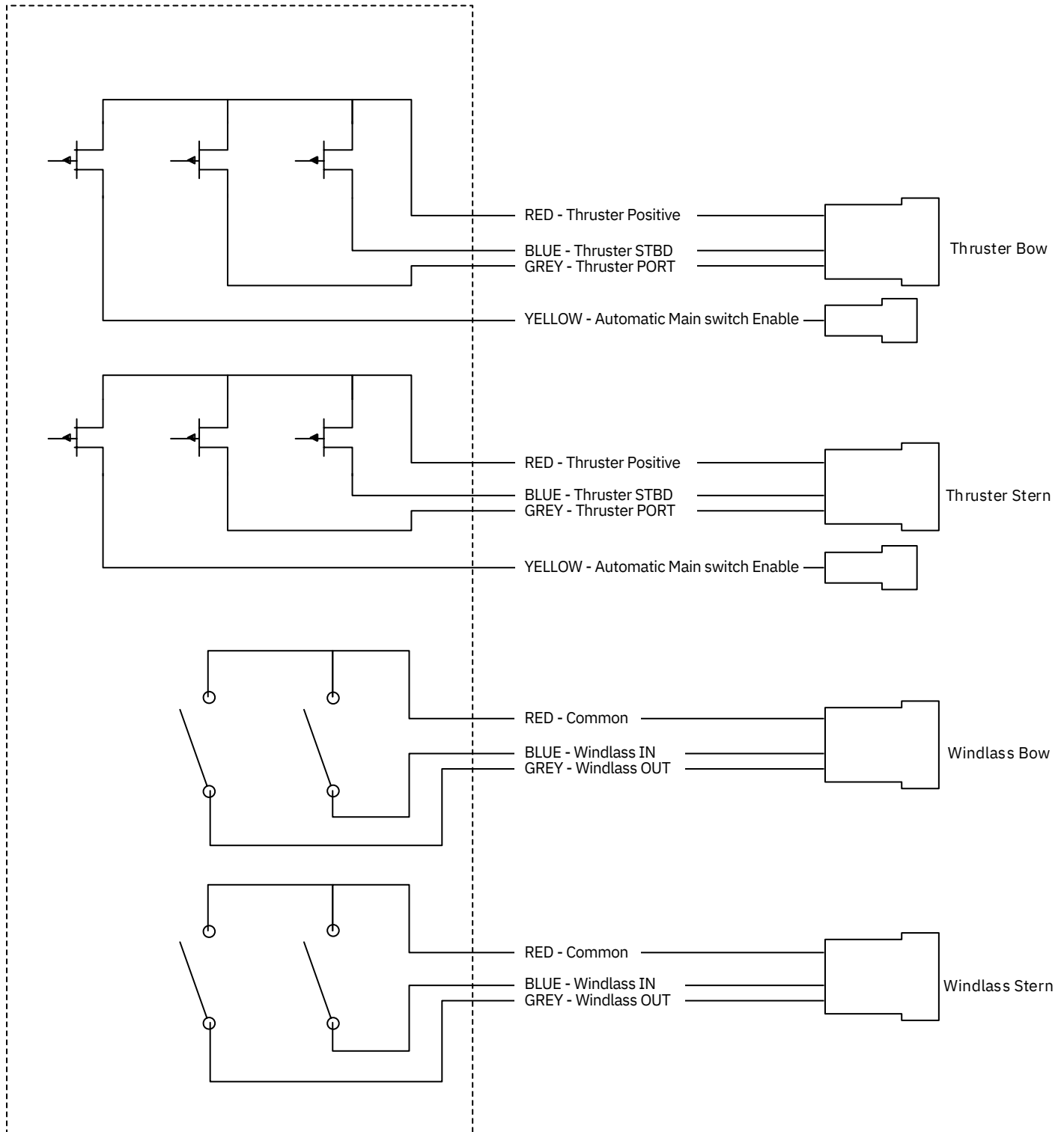



MG_0197

EN

Programming Additional Transmitters/ Remote Controls

MC_0181

! Please refer to the graphic for special considerations relating to your model !

The original transmitter and receiver have the same factory pre-set code so that no programming is necessary. When additional transmitters remote controls are to be used, the additional transmitters/remote controls have to be paired with the receiver.

1. Be sure that there is power on the receiver (Green status LED blinking) and that the transmitter that should be paired is off.
2. Push the Pair Button on the receiver to put the receiver in pairing mode (as shown above). Both red and green LED's should start to blink simultaneously.
3. Within 10s after the receiver pair button is pushed, set the transmitter in pairing mode by holding the off button and pressing both "ON" buttons at the same time, all the transmitter LED's turn on indicating that it is set in pairing mode. When a pairing signal is received from the receiver the transmitter LED's while turn off and the system is ready to be used. If no pairing signal received within 10s the transmitter will leave the pairing mode.
4. Additional transmitters/remote controls must be programmed according to step 2-3. You can pair up to 4 transmitters/remote controls.
5. To clear all transmitters/remote controls paired with the receiver hold the pair button on the receiver for approximately 10s until the red and green led stop blinking. When the LED's stop blinking release the pair button, the green led will again start to blink when the receiver has completed the reset process. The receiver is then ready to pair with up to four transmitters/remote controls. Take time to practice operation in open water to become familiar with the thruster and to avoid damages to your boat or people.

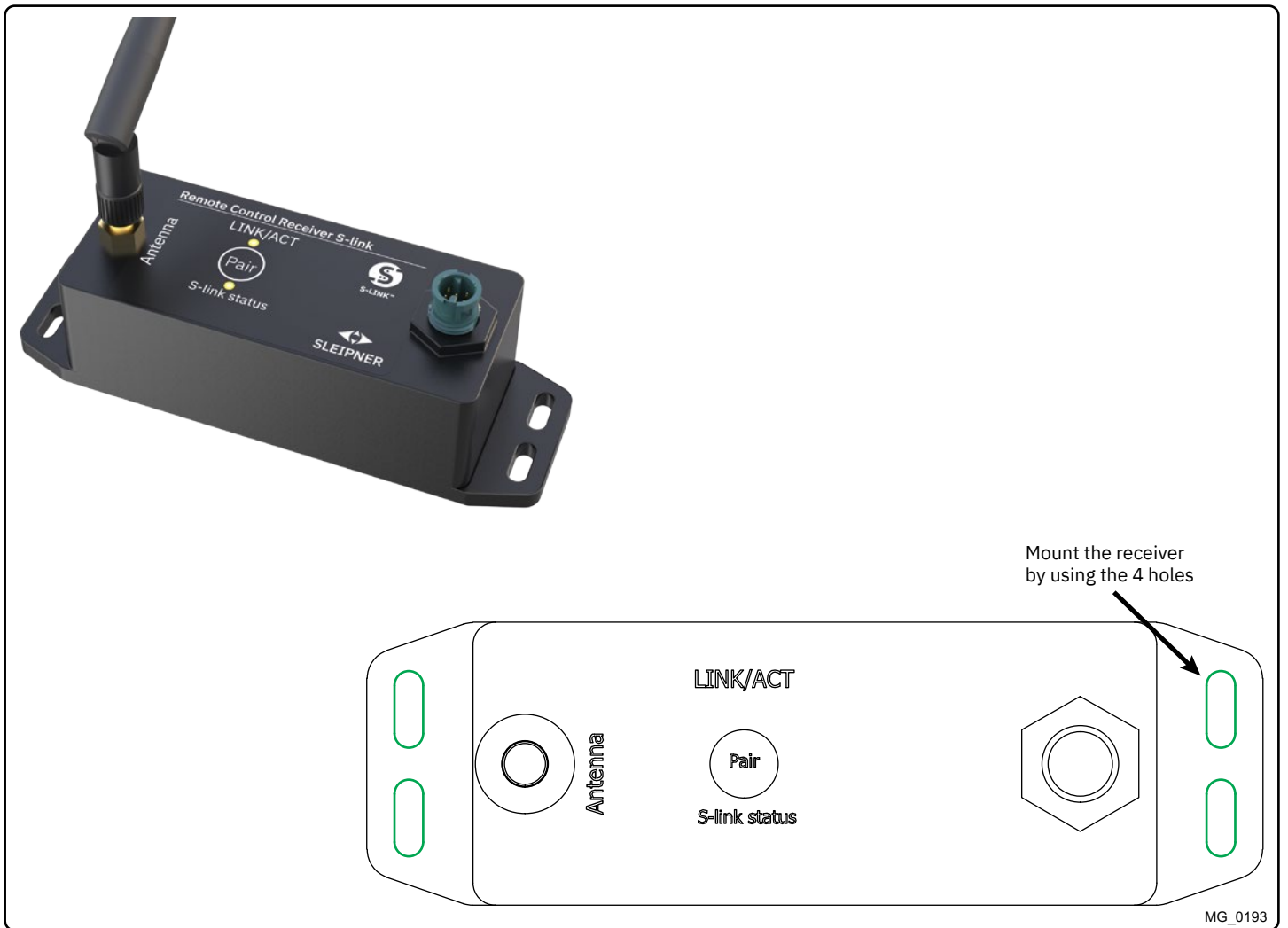

MG_0193

EN

S-Link Receiver Installation

MC_0183

! Please refer to the graphic for special considerations relating to your model !

- Install the receiver minimum 1 meter (3ft) from high power cables and data communication cables or other sources of electrical interference, i.e. navigation instruments, radio communication devices, electric motors and generators.
- Install the receiver minimum 1 meter (3ft) above sea level.
- Install the receiver outside of shielded areas for radio signals, i.e. boxes made of metals or other material with shielding properties.
- Install the receiver in a dry environment, where no condensation can enter the unit. (The receiver assembly is not waterproof.).
- Mount the receiver using the four holes.
- The receiver is powered by the S-link cable.
- Connect the supplied wiring harnesses to the receiver unit according to the wiring diagram. Connect thrusters and windlasses to the appropriate connectors according to the diagram.
- For use with other windlass brands, connections must be determined by the installer according to the out put signals diagram.

Technical Wiring Diagram

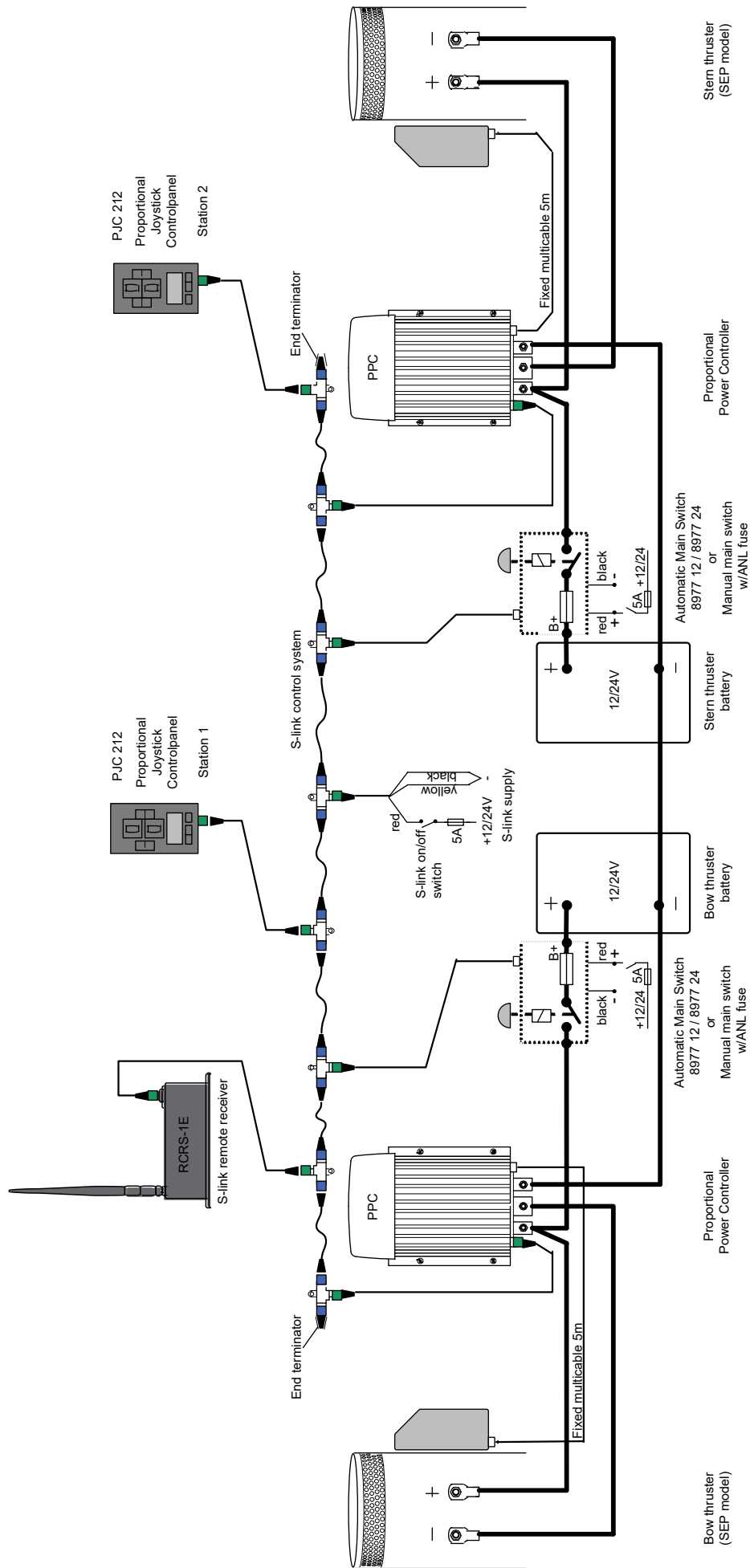

Observe PPC battery terminal polarity !



MG_0200

EN

Programming Additional Transmitters/ Remote Controls

MC_0202

! Please refer to the graphic for special considerations relating to your model !

The original transmitter and receiver have the same factory pre-set code so that no programming is necessary. When additional transmitters remote controls are to be used, the additional transmitters/remote controls have to be paired with the receiver.

1. Be sure there is power on the receiver (S-link status LED is blinking green or continuous green) and the transmitter that should be paired is off.
2. Push the Pair Button on the receiver to put the receiver in pairing mode (as shown above). The LINK/ACT LED should start to blink.
3. Within 10s after the receiver pair button is pushed, set the transmitter in pairing mode by holding the off button and pressing both "ON" buttons at the same time, all the transmitter LED's turn on indicating that it is set in pairing mode. When a pairing signal is received from the receiver the transmitter LED's while turn off and the system is ready to be used. If no pairing signal received within 10s the transmitter will leave the pairing mode.
4. Additional transmitters must be programmed according to step 2-3. You can pair up to 4 transmitters.
5. To clear all transmitters paired with the receiver hold the pair button on the receiver for approximately 10s until the LINK/ACT LED stops blinking. When the LED stops blinking release the pair button. The receiver is then ready to pair with up to four transmitters.

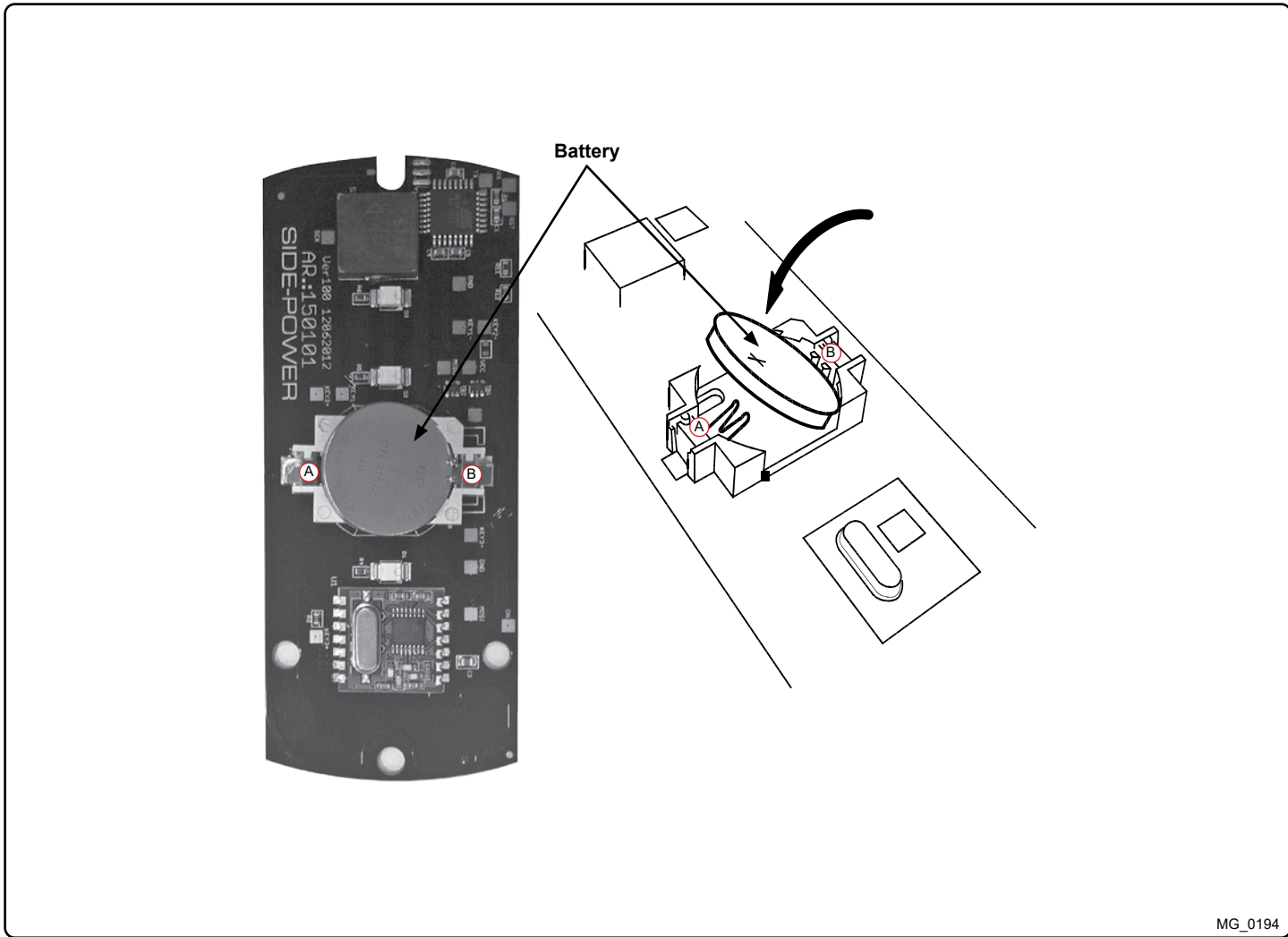

MG_0194

EN

Transmitter Installation and Battery Replacement

MC_0178

! Please refer to the graphic for special considerations relating to your model !

1. Open the transmitter case by removing the 3 torx screws.
2. Remove the battery by inserting a screwdriver or similar between battery and holder at point A and flip the battery out, taking care not to damage the battery grips at point B.
3. Insert the new battery (Type CR2032, 3V - Brand name recommended). Ensure to insert the battery with the positive pole up diagonally into the battery holder, ensuring that the edge of the battery is under the battery grips (B). Press the battery down until secured at point A.
4. Close the transmitter. Put the cover back in place, ensure that the rubber seal between remote upper and the lower part is located correctly. Place the 3 screws (remember sealing washer) in their recessed holes and tighten carefully.

IMPORTANT

Before working on the transmitter, deactivate the transmitter and the receiver (push "OFF" on the transmitter(s)) and turn off the power to the receiver as well as the thruster main switch.

IMPORTANT

Failure to follow the Considerations and precautions can cause serious injury / damage and will render all warranty given by Sleipner Motor AS VOID.

- Ensure you know the location of the main battery switch that disconnects the thruster from all power sources (batteries) so the thruster can be turned off in case of serious malfunction.
- Always turn the control device off when the thruster is not in use.
- The maximum continuous run time of the electrical thruster is approximately 3 minutes. The electro motor has a built-in thermal cut-off switch that will shut off the electro-motor if it is overheating and re-engage when it has cooled down. Consider this when planning your manoeuvring.
- As above the thruster will limit its total running time per period. Do not count on the thruster to hold you in a strong current or side wind for extensive periods. Depending on the surrounding temperatures etc. the thruster will be able to run approximately 10 % of the time.
- Never use thrusters close to objects/ persons or animals in the water, as the thruster will draw objects into the tunnel and contact with the rotating propellers will cause serious injuries and damage the thruster.
- With the boat on land, only run the thruster for a fraction of a second, as without resistance it will accelerate very fast to a potentially damaging rpm.
- While the thruster is in the air, ensure that the propellers have come to a complete stop before performing a directional change of the thruster, as it might cause damage to the thruster.
- If the thruster stops giving thrust while the electro-motor is running, there is possibly a problem in the drive system. You must immediately stop running the thruster and turn it off. Running the electro motor for more than a few seconds without resistance from the propeller can cause serious damage to the electro motor.
- When leaving the boat always turn off the main power switch for the thruster.
- We advise keeping the main engine(s) running while using the thruster. This will keep the batteries in a good charge condition. It will also give better performance to the thruster, a higher voltage at the thruster results in a higher torque (power) in the electro motor.
- Please note the performance of the thruster strongly depends on the voltage available at the electro motor. This voltage will decrease over time because ageing batteries have reduced capacity. Installing new batteries will bring back the thruster to the original level.
- Ensure only one control is used at the same time, if two panels are operated in opposite directions at the same time the thruster will not run. If both are operated in the same direction, the thruster will run in this direction.
- If the thruster is not performing or functioning as usual, the cause must be found and corrected as soon as possible to avoid causing any other or further damage to the equipment. You must also turn off the main battery switch immediately in case the problem is of electric origin.
- It is the owner/ captain/ other responsible parties full responsibility to assess the risk of any unexpected incidents on the vessel. If the thruster stops giving thrust for some reason while manoeuvring you must have considered a plan on how to avoid damage to persons or other objects.
- The primary purpose of the thruster is to manoeuvre/ dock the vessel. Forward/ reverse speed must not exceed 4 knots when operated.
- Never use a windlass close to somebody in the water, an unexpected drop of the anchor can cause serious injuries.

! Please refer to the graphic for special considerations relating to your model !

Take time to practice operation in open water to become familiar with the thruster and to avoid damages to your boat or people.

How to use a Bow Thruster

1. Turn on the main power switch for the bow thruster. **(NB: Always turn off the main power switch when not on-board.)**
2. Turn on the control panel by pushing both "ON" buttons on the original Side-Power panel simultaneously. **(NB: If another type of control is installed, push the On/Off switch for the bow thruster.)**
* Turn off the control panel by pushing both "OFF" button
3. To Turn the bow in the desired direction push the red button for port movement or the green button for starboard.
- For joystick control, move the joystick in the direction you wish the bow to move.
- Other controls like foot switches or toggle-switches on the throttle can be used. Engage the port control, the bow will turn to port etc.
4. Depending on the sideways speed of the bow, you must disengage the control device shortly before the bow is in the desired position. **(NB: The boat will continue to move after disengaging the thruster control.)**

How to use a single stern thruster

Due to space limitations, a vessel may only have a stern thruster. In this case, the stern thruster is used in the same way as a single bow thruster for moving the boat's stern. Follow the above instruction for operation use.

How to use a combined bow and stern thruster

The combination of a bow and stern thruster offers total manoeuvrability to the boat and the ability to move the bow and the stern separately from each other. This enables you to move the boat sideways in both directions and turn the boat around its axis 360° staying stationary.

NB: At any significant cruising speed (+1-2 kn) the side thruster will have little effect to steer the vessel.

How to use the windlass

1. Turn the main power switch for the windlass on. Turn on the power to the receiver.
2. Turn on the transmitter by pushing the transmitter's two "ON" buttons. The remote system is now activated and then turns off automatically appr. 4 min. after the last usage.
3. Please consult your windlass manual for use and precautions.



Activating the bow thruster



Activating the stern thruster



Activating both bow and stern thruster to push the boat sideways



Activating both bow and stern thruster to rotate the boat on axis



Activating lowers Anchor/Windlass



Activating raises Anchor/Windlass



State	LED status	Alarm status
Transmitter ON	The yellow LED's blink each second	No sound
Buttons activated	The yellow LED's blink fast	No sound
Pairing mode	All LED's on	No sound
Connection lost	Red LED is blinking once each second	3 beeps from the buzzer each second
Low battery	Red LED blink	One beep

State	LED status
Power on the receiver and no transmitter connected	Green LED is blinking
Power on the receiver and at least one transmitter connected	Green LED on
No power to the receiver.	Both LED is off
Receiver in pairing mode	Both the red and green LED blinking

State	LED status	Alarm status
Transmitter ON	The yellow LED's blink each second	No sound
Buttons activated	The yellow LED's blink fast	No sound
Pairing mode	All LED's on	No sound
Connection lost	Red LED is blinking once each second	3 beeps from the buzzer each second
Low battery	Red LED blink	One beep

State	S-Link LED status
No power to receiver	OFF
OK, S-Link Bus active	Continuous GREEN
No activity on S-Link bus	Blinking GREEN

State	Link/ACT LED status
Remote off	OFF
At least one transmitter connected	ON
Device in pairing mode	Blinking

Find your local professional dealer from our certified worldwide network for expert service and support.

visit our website www.sleipnergrou.com/support

For additional supporting documentation, we advise you to visit our website www.sleipnergrou.com and find your Sleipner product.

1. Sleipner Motor AS (The "Warrantor") warrants that the equipment (parts, materials and embedded software of products) manufactured by the Warrantor is free from defects in workmanship and materials for the purpose for which the equipment is intended and under normal use and service (the "Warranty").
2. This Warranty is in effect for two years (Leisure Use) or one year (Commercial and other Non-leisure Use) from the date of purchase by the end user (for demonstration vessels, the dealer is deemed as end user).
3. This Warranty is transferable and covers the equipment for the specified warranty period.
4. The warranty does not apply to defects or damages caused by faulty installation or hook-up, abuse or misuse of the equipment including exposure to excessive heat, salt or fresh water spray, or water immersion except for equipment specifically designed as waterproof.
5. In case the equipment seems to be defective, the warranty holder (the "Claimant") must do the following to make a claim:
 - (a) Contact the dealer or service centre where the equipment was purchased and make the claim. Alternatively, the Claimant can make the claim to a dealer or service centre found at www.sleipnergrou.com. The Claimant must present a detailed written statement of the nature and circumstances of the defect, to the best of the Claimant's knowledge, including product identification and serial nbr., the date and place of purchase and the name and address of the installer. Proof of purchase date should be included with the claim, to verify that the warranty period has not expired;
 - (b) Make the equipment available for troubleshooting and repair, with direct and workable access, including dismantling of furnishings or similar, if any, either at the premises of the Warrantor or an authorised service representative approved by the Warrantor. Equipment can only be returned to the Warrantor or an authorised service representative for repair following a pre-approval by the Warrantor's Help Desk and if so, with the Return Authorisation Number visible postage/shipping prepaid and at the expense of the Claimant.
6. Examination and handling of the warranty claim:
 - (a) If upon the Warrantor's or authorised service Representative's examination, the defect is determined to result from defective material or workmanship in the warranty period, the equipment will be repaired or replaced at the Warrantor's option without charge, and returned to the Purchaser at the Warrantor's expense. If, on the other hand, the claim is determined to result from circumstances such as described in section 4 above or a result of wear and tear exceeding that for which the equipment is intended (e.g. commercial use of equipment intended for leisure use), the costs for the troubleshooting and repair shall be borne by the Claimant;
 - (b) No refund of the purchase price will be granted to the Claimant, unless the Warrantor is unable to remedy the defect after having a reasonable number of opportunities to do so. In the event that attempts to remedy the defect have failed, the Claimant may claim a refund of the purchase price, provided that the Claimant submits a statement in writing from a professional boating equipment supplier that the installation instructions of the Installation and Operation Manual have been complied with and that the defect remains.
7. Warranty service shall be performed only by the Warrantor, or an authorised service representative, and any attempt to remedy the defect by anyone else shall render this warranty void.
8. No other warranty is given beyond those described above, implied or otherwise, including any implied warranty of merchantability, fitness for a particular purpose other than the purpose for which the equipment is intended, and any other obligations on the part of the Warrantor or its employees and representatives.
9. There shall be no responsibility or liability whatsoever on the part of the Warrantor or its employees and representatives based on this Warranty for injury to any person or persons, or damage to property, loss of income or profit, or any other incidental, consequential or resulting damage or cost claimed to have been incurred through the use or sale of the equipment, including any possible failure or malfunction of the equipment or damages arising from collision with other vessels or objects.
10. This warranty gives you specific legal rights, and you may also have other rights which vary from country to country.

At Sleipner we continually invest to develop and offer the latest technology in marine advancements. To see the many unique designs we have patented visit our website www.sleipnergrou.com/patents

Dotted lines for notes.

© Copyright Sleipner Motor AS, 2021

The information given in the document was correct at the time it was published.

However, Sleipner Motor AS can not accept liability for any inaccuracies or omissions it may contain. Continuous product improvement may change the product specifications without notice.

Therefore, Sleipner Motor AS can not accept liability for any possible differences between product and document.

Register your product and learn more at www.sleipnergroun.com



SLEIPNER AS

P.O. Box 519

N-1612 Fredrikstad

Norway

www.sleipnergroun.com

Made in Norway

